

Ecology

Environment-friendly Design M2044TC

MURATEC for the first time in punch press history, introduced in 1994, a new concept in ram drive technology, which incorporated a toggle mechanism driven by an AC servo motor. Hydraulic oil-less sheet metal processing on the M2044TC enables ecological machine operations saving environmental natural resources.



Economy

Energy-efficient Operation

In the M2044TC, the punching energy is generated instantaneously using an advanced servo motor controlled ram drive. The ram servo motor consumes power only during the punching process, thus reducing running costs drastically.

Hydraulic Oil-less Operation

The absence of a hydraulic unit on the M2044TC gets rid off hydraulic unit and oil maintenance, disposal of waste oil, and periodic oil replacement. This saves on hydraulic oil and maintenance costs, thus reducing running costs.

Energy Saving NC Control

The M2044TC machine's LCD screen goes in energy saving mode when the NC keyboard is not in operation for a parametric set time period. The screen can be displayed again if any NC operation key is touched.

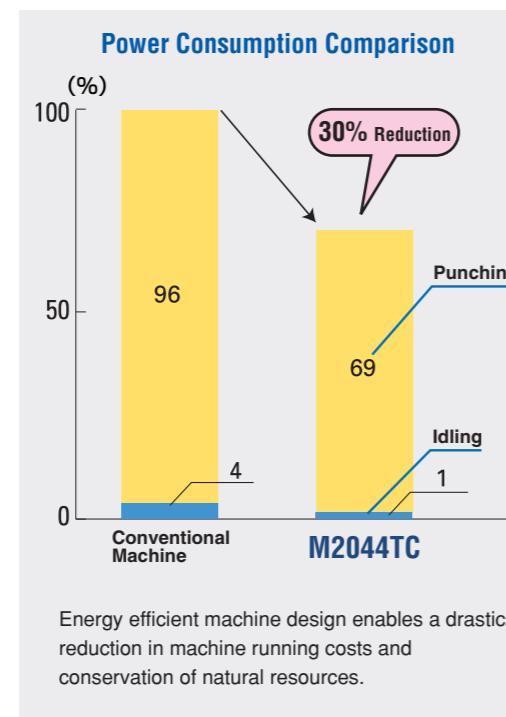

Easy to operate

User-friendly Machine Operation

The M2044TC incorporates all the basic necessary functions for sheet metal processing with simple operations for easy and quick machine utilization.

Quick Machine Start

The M2044TC does not require machine warming-up cycle. The operator can start the production without waiting for the machine warming-up period like hydraulic or conventional machines.



Turret Layout

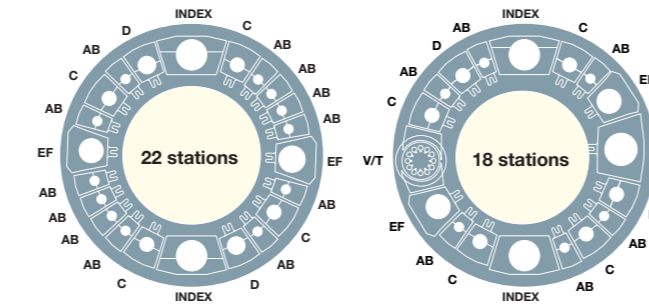

Specifications

Punching capacity	200 kN (20.4 metric tons) [22.4 US tons]
Maximum sheet thickness	6.35 mm [0.25"]
Y-axis stroke	1335 mm [52.56"]
X-axis stroke	1300 mm [51.18"]
Maximum sheet size (Y x X)	Without repositioning 1250 mm x 1250 mm [49.21" x 49.21"] With one reposition 1250 mm x 2500 mm [49.21" x 98.43"]
Throat depth	1300 mm [51.18"]
Maximum allowable sheet weight	105 kg [231 lbs]
Hit rate	25 mm pitch 240 hpm
1.0 t	
8.3 mm stroke 1 mm pitch	900 hpm
Axis speed (X and Y-axis)	75 m/min [2953 in/min]
Simultaneous axis speed	106 m/min [4173 in/min]
Punching accuracy	± 0.1 mm [± 0.004"]
Turret index speed	33 rpm
Compressed air	Quantity 100 NL/min [35 ft ³ /min] Pressure 0.5 MPa [71 PSi]
Power Supply	18 kVA

Option

- Slug suction unit
- Varimark
- Varitool
- Deburring tool control

■ Safety Specification
Machines built with CE-safety conformity are available as option.

MURATA MACHINERY, LTD. MACHINE TOOLS DIVISION

International Business Dept.
2, Nakajima, Hashizume, Inuyama-shi, AICHI 484-8502, JAPAN
TEL: +81-(0)568-61-3645 FAX: +81-(0)568-61-6455

Headquarters
136, Takeda-Mukaishiro-cho, Fushimi-ku, KYOTO 612-8686, JAPAN
TEL: +81-(0)75-672-8138 FAX: +81-(0)75-672-8691
<http://www.muratec.co.jp>
e-mail info@muratec.co.jp



MURATA MACHINERY USA, INC
2120 Queen City Drive, P.O.Box 667609,
Charlotte, N.C. 28208, U.S.A.
TEL: +1-704-875-9280 FAX: +1-704-392-6541
<http://www.muratec-usa.com>

MURATA MACHINERY EUROPE GmbH
Hanns-Martin-Schleyer-Straße 3, D-47877, Willich, GERMANY
TEL: +49-(0)2154-914-250 FAX: +49-(0)2154-914-283
<http://www.muratec-europe.de/>
e-mail info@muratec.de

MURATA DO BRASIL COMERCIO
E REPRESENTACAO DE MAQUINAS LTDA.
Estrada de Santa Isabel, 3383-KM 38,5,
Itaquaquecetuba-SP, CEP 08599-000, BRASIL
TEL: +55 (11) 4648-6222 FAX: +55 (11) 4648-6737
<http://www.muratec.com.br>
e-mail muratec@muratec.com.br

MURATA (THAILAND) CO., LTD.
896/14 S.V.City Building 1, 9th Floor, Rama 3 Road
Bangpongpan, Yannawa, Bangkok 10120, THAILAND
TEL: +66-(0)2294-7734-40 FAX: +66-(0)2294-7732

M2044 TC

CNC Servo Motor Driven Ram Turret Punch Press

Tooling Range

Range	Round punch	No. of stations	
		22ST/2-index	18ST/3-index
A	~12.7 mm [0.5"]	12	6
B	~25.0 mm [1.0"]		
C	~38.0 mm [1.5"]	4	4
D	~50.0 mm [2.0"]	2	2
E	~64.0 mm [2.5"]	2	2
F	~75.0 mm [3.0"]		
G	~89.0 mm [3.5"]	—	1
I/T	~75.0 mm [3.0"]	2	3
V/T	~12.7 mm x 12 [0.5" x 12]		
V/M	20,40 characters		

* A range is round only.
* With Auto-index station, Index tool(I/T), varitool(V/T) or VARIMARK(V/M) can be selected as options in desired combination.

Floor Plan

Floor space 2700 mm x 4570 mm [8'10" x 15"]
Weight 8.8 tons [19400 lbs]
Height 2210 mm [7'3"]

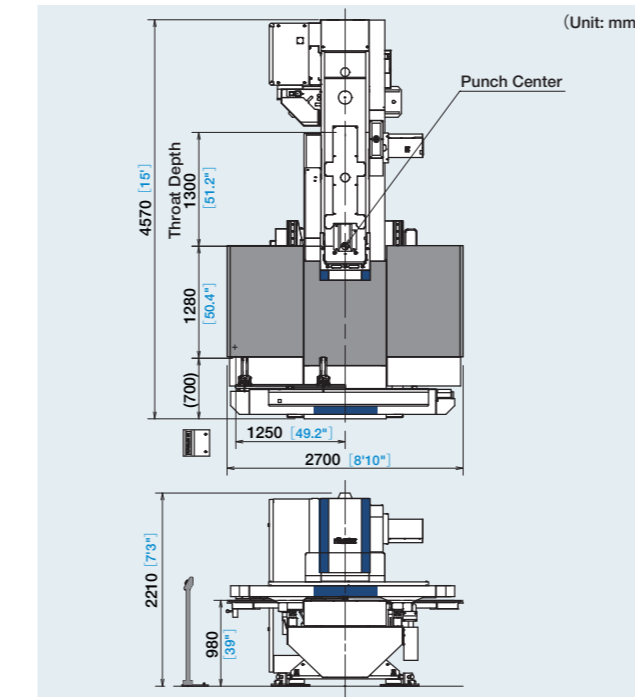

* Machine appearance may differ to that shown in the catalogue pictures.
* All specifications are subject to change without advance notice.



MOTORUM SERIES

M2044 TC

CNC Servo Motor Driven Ram Turret Punch Press



Ecology
Economy
Easy to operate

M2044 TC

CNC Servo Motor Driven Ram Turret Punch Press

Environment Friendly

Energy Efficient

Operator Friendly

The next generation



Simple New Drive Ram Mechanism

Muratec electric servo driven punch press has been evolving continuously! The newly engineered ram drive of M2044TC has become more simple and more rigid. With the elimination of the Cam Drive Cylinder, the servo motor can control the ram stroke directly, resulting in higher punch speeds and productivity. The reduction of the number of components has maximized stability during operations, decreasing maintenance and increasing longevity. The new drive has a more efficient motor that runs cooler and requires less energy.

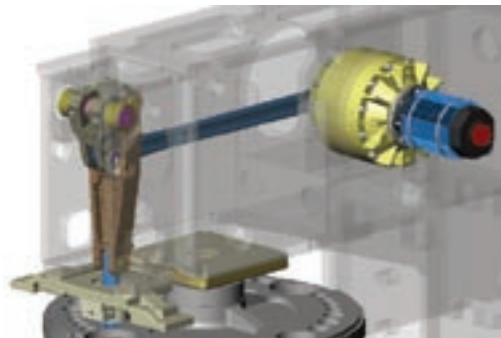

Punch-in, Pull-Out Type Wiedemann Tooling

The positive Punch-in and Pull-out design of the ram, which is mechanically linked to the punch holder during the punching cycle, guarantees positive punching. This design has already been field proven for its high strength, precision and simplicity of tooling. By combining this feature with the newly innovated servo motor driven ram, the reliability of the machine has been greatly enhanced.

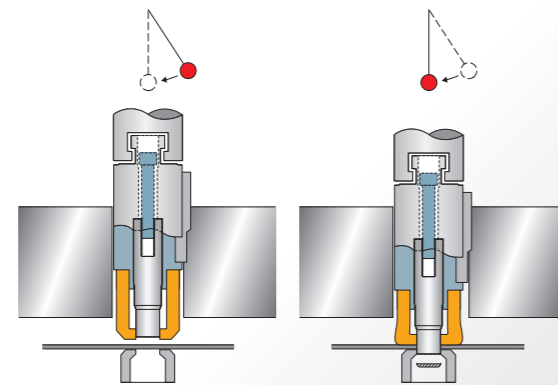

Ram Operation Patterns

Precise RAM control is delivered through the servo motor drive. This precise control enables Ram Operation Patterns for a wide range of processes.

High speed punching:

The servo motor is driven alternately between hover height and bottom dead center with a back and forth motion. The hover height position is adjusted based on material type and thickness. This control of the ram stroke provides high speed punching and efficient productivity.

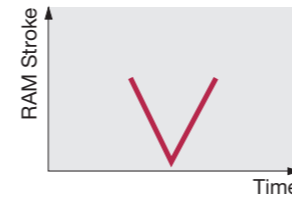

Forming Operation:

Using variable servo motor control ram stroke between top dead center and bottom dead center, the best results and excellent performance in forming tool operation can be achieved. An important benefit of controlling the ram stroke is to specify a dwell time at bottom dead center and allow material flow during the forming operation.

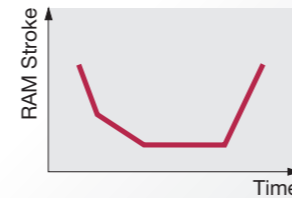

200 kN Punching Capacity

The M2044TC is designed to meet the sheet metal challenges of the new millennium. This rugged punch press delivers 200 kN of punching force, which is sufficient to process standard fabricating requirements of punching and forming. The design has been successfully tested for continuous 100,000 hits in 6 mm thick work sheet for full tonnage.

Maximum Sheet Metal Processing Tool Size (Unit: mm)

Thickness	Round	Square	Rectangle
3.2	Dia.88	57	10×78 *1
4.5	Dia.54	42	10×75 *1
6.0	Dia.37	29	10×48

(Punch with shear)

Louwer: Width 18 mm,
Length 64 mm,
Thickness 3.2 mm



Emboss: Dia. 37 mm,
Thickness 3.2 mm



*1 : 18 stations turret required

Retractable Repositioning Pad Buttons

Retractable repositioning pad buttons are raised automatically for clamping the worksheet during the repositioning operation only. During normal punching when the worksheet is moving over the repositioning pad buttons, the buttons are retracted downward which eliminates scratches on the under side of the worksheet. This enhances the quality of the finished worksheet.

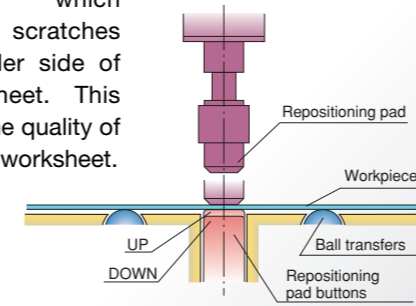

Slug Suction Unit (Option)

The slug suction unit allows for better punching quality and minimizes the slug pull-back problem for thin worksheets. This function is extremely useful while processing worksheets having scratch prevention films. The air suction helps to detach cut films from the workpiece.

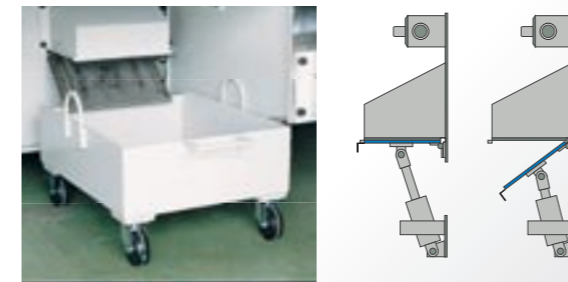

Varitool / Varimark (Option)

The Varitool is available in 12 tool configurations. Using Varitool in the Auto-index station increases the turret tool capacity. The 12-station tool configuration has tool sizes up to 12.7 mm dia. The Varimark is built-in with 20 or 40 standard alphanumeric and punctuation characters for stamping on the worksheet.



Operator Friendly

Scheduling Function

Scheduled job production guides the operator on a standalone machine. Program NC and scheduling data is automatically downloaded to the machine. Required tooling, material and work holder setup information is also displayed.



Processing Simulation Function

The current processing position during machine operation is displayed in red. This allows recognition at a glance of the punching sequence and production progress.



*Above function requires Muratec original program format.

Machine Control Functions

Various utilities are available to the operator. Optional log files can be viewed for machine operation and program start/finish times. Also machine alarm history can be viewed.



Expanded Processing Condition List

The processing modes of 1000 tool types with 5 pattern setups can be registered for 30 material types and thicknesses. This allows for setting the detailed processing conditions of all the customer's tooling.



Tool Management

A library of all the machine tooling is maintained on the control. The hit counts for all tools and dies are then tracked to allow scheduled maintenance when the hit counts exceed the predetermined maximum count.



*Above function requires Muratec original program format.

Turret Monitor Function

Displays information on current tooling set in the turret. This allows tooling in scheduled jobs to be analyzed and it automatically determines when tool changes are required.



*Above function requires Muratec original program format.